

# DIGITAL WIRELESS 7" LCD MONITORING SYSTEM WITH SD CARD RECORDING

INSTRUCTION MANUAL



## Features

- Digital wireless technology provides excellent image quality and clarity
- Interference free, secure and private signal
- Up to 300ft wireless transmission range <sup>①</sup>
- Two-way audio communication
- SD card recording
- Safety warning feature notifies you when out of range
- System expandable up to 4 cameras <sup>②</sup>

<sup>①</sup> Maximum open space transmission range. The actual range is dependent upon building materials and other obstructions in path of wireless signal.

<sup>②</sup> Additional cameras sold separately.

## Camera Features

- VGA resolution camera
- Night vision allows for low light viewing up to 40 feet / 12 meters <sup>③</sup>
- Built-in microphone
- Weatherproof for outdoor use
- PIR Sensor for motion detection

<sup>③</sup> IR illumination range of 40ft./12m under ideal conditions. Objects at or beyond this range may be partially or completely obscured, depending on the camera application.

## Receiver Features

- 7" color LCD monitor/receiver with superior image quality
- Auto recording, manual recording and schedule recording
- Remote control for receiver portable operation
- Displaying stored pictures in scan mode (screen saver)
- Can be desktop stand or wall mounted
- Supports quad image view

## Getting Started

The system comes with the following components:



Check your package to confirm that you have received the complete system, including all components shown above.

# Wireless Receiver

## Front Controls

1. **LCD Screen** – Displays video from the camera(s) or displays system operations.

2. **IR Window** – Receives signals from remote control. It is recommended to point to this IR window when using remote control for receiver operation.

3. **(Rec) Manual** – Press the button to start recording, press it again to stop recording. In this manual recording mode, the indication LED located on the **Manual** button will be on.

**(Rec) Auto** – Press the button to switch the system to automatic recording mode. In auto recording mode, the indication LED located on **Auto** button will be on and the receiver starts recording when motion detected by a camera. The recording time can be set to 15s or 30s. Press the button again to cancel automatic recording.

4. **(Channel) Manual** – Press the button to manually switch between all activated cameras. Once the button is pressed, the indication LED located on **Manual** button will be on.

**(Channel) Auto** – Press the button to view cameras in automatic switching mode. Once the button is pressed, the indication LED located on **Auto** button will be on.

5. **Del/Scan** – In viewing mode, press the button to switch the receiver to scan mode. In scan mode the LCD screen is turned off or displays a static picture, and the system continuously scans all available cameras, and the indication LED on **Del/Scan** button will be on.

If motion is detected by the camera(s), the receiver will beep and display the image from the triggered camera. The receiver will return to scan mode about 5 seconds after the alarm has completed. Press **Del/Scan** or **(Channel) Auto** buttons to exit from scan mode to automatic switching mode, press **(Channel) Manual** button to exit from scan mode to manual switching mode.

In playback interface, press the button to delete recorded files from SD card.

6. **MENU Button** – Press to access the receiver menu. Press the button again to exit.

7. **Joystick** – In viewing mode, press down the joystick to enter playback interface for recorded videos.

In quad mode, push the joystick to a certain number to view the image from the corresponding camera in full screen mode.

In menu mode, use the joystick (UP/DOWN/LEFT/RIGHT ▲▼◀▶ arrows) for system setting or menu selection, and press it down to confirm the selection or setting.

In playback mode, use the joystick to play/pause, stop, forward, backward, etc.

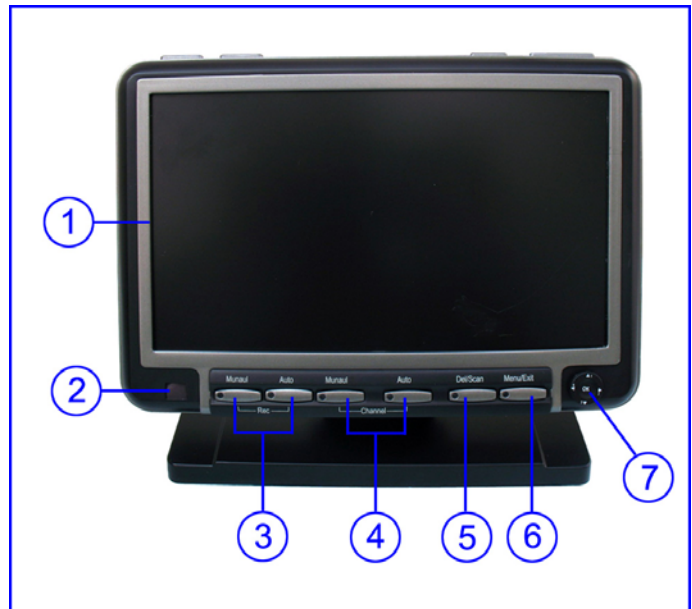

## Top Controls

**8. Power Button** – Press to turn the receiver ON or OFF.

**9. TV/AV** – When connecting the receiver to TV or VCR/DVR, press the button to output audio/video. When outputting audio and video, the LCD screen will be switched to blank.

**10. Quad** – Press **Quad** button to view the images in quad mode. Press **Quad** or **(Channel) Auto** buttons to exit from quad mode to automatic switching mode, press **(Channel) Manual** button to exit from quad to manual switching mode.

**11. Vol / Adj:** Press the left part to decrease the volume and press the right part to increase the volume.

## Side Controls

**12. TALK Button** – Press down and hold this button to talk back to the camera which's image is displayed on the screen.

**13. SD Card Slot** – Insert SD card to this SD card slot for both video and audio recording.

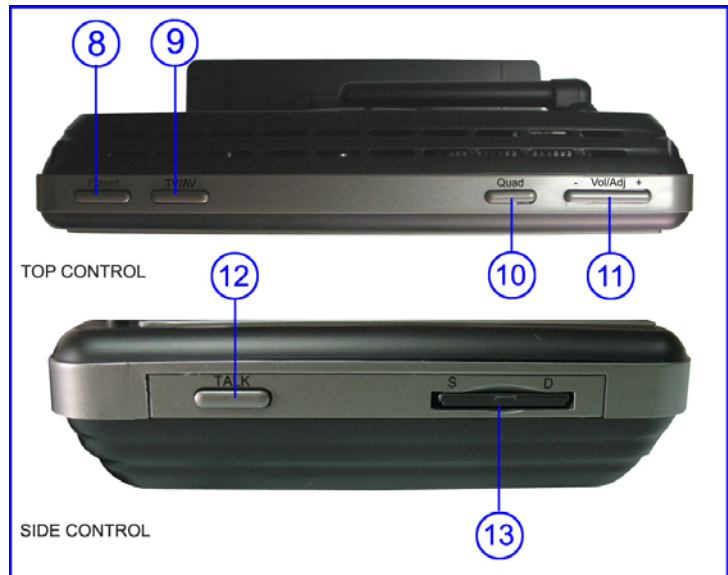

## Back Controls

**14. Receiver Antenna** – receives & sends signals from or to the camera(s). Adjust the antenna to vertical position when the signal reception is not good.

**15. Speaker** – Produces the sound transmitted from the camera(s).

**16. A/V Out Port** – Connect the included A/V cable to view video from the receiver on a TV or monitor, or record to a VCR/DVR.

**17. Microphone** – Receives sounds from the area near the receiver and transmits sound from the receiver to the camera (only when **TALK** Button is pressed down and held).

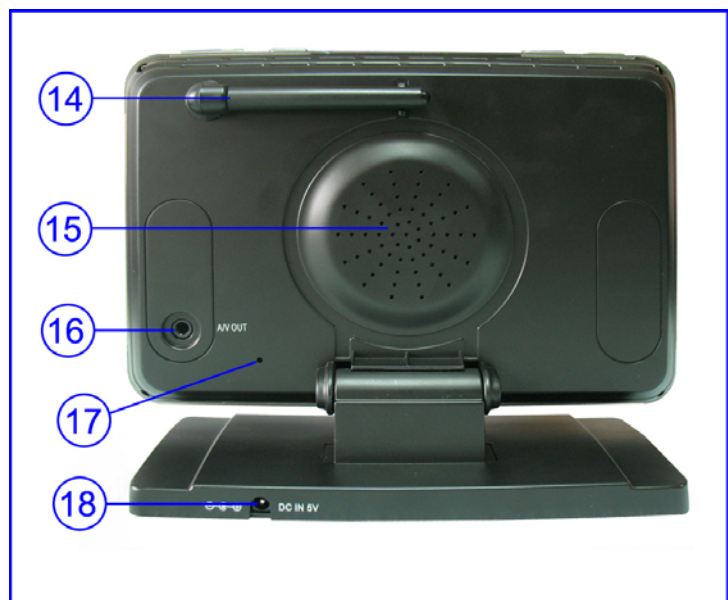

**18. DC 5V Power Input** – Connect the included DC 5V power adaptor to power the receiver.

## Wireless Receiver Installation

1. Before receiver installation, choose one installation method from below 2 methods:

1). Desktop or table stand.

For this method, you only need to place the receiver on a desktop.

2). Wall mounting

Decide where to mount the receiver first. Make sure the range between the position and the nearest power output port is no more than 5 feet. Also, the range between the position and TV or VCR/DVR should be no more than 5 feet.

Drill two holes on the wall where you decide to install the receiver. Insert a plastic anchor to each hole and fix a screw into the plastic anchor. Insert the screws into the two holes located on the bottom of receiver and then push down the receiver.

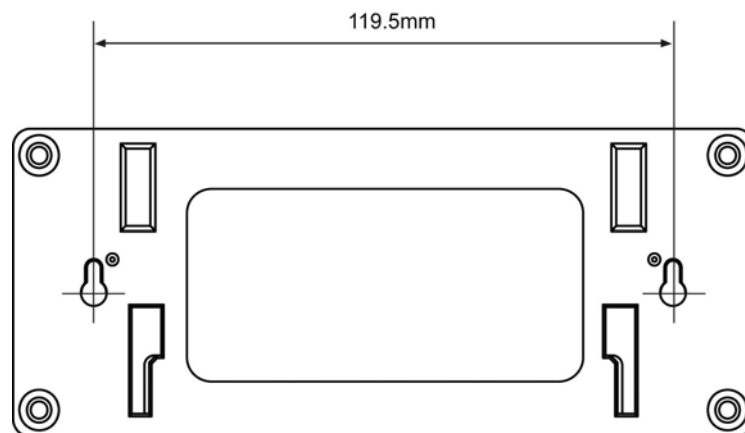

Adjust the receiver for best viewing angle.

2. After the receiver is well positioned, plug the AC adaptor power output cable into the 5V POWER input of the receiver, and plug the power plug into a wall outlet or surge protector.

3. If you wish to view the receiver images on a larger screen, connect one end of the included AV cable to the AV output of receiver, and connect the other end to the Video IN (Yellow) and Audio IN (White) ports on the TV, VCR or other viewing/recording devices.

Note: When outputting Audio/Video to TV, etc, press the AV button on the remote control to output audio and video to TV.

The receiver installation is now completed.

## Wireless Camera

### Front & Side Controls

**1. Camera Antenna** – Sends & receives signals to or from the receiver.

**2. AC Adaptor Jack** – Plug the AC adaptor to the jack for camera's power supply.

**3. Wall Mounting Bracket** – Use the bracket to mount the camera on a wall or other flat surfaces.

**4. IR LEDs** – Infrared LEDs provide viewing in no/low light conditions

**5. Lens** – Catches the video in front of the lens and transmits video from camera to receiver.

**6. PIR Sensor** – Detects motion in front of the lens and emits detection signal to transmitter.

### Bottom Controls

**7. Microphone** – Receives sounds from the area near the camera, and transmits sound from the camera to the receiver.

**8. Speaker** – Produces the sound transmitted from the receiver.

### Back Controls

**9. Pair Button** – The pair button is located on the back of the camera, it is used to pair the camera with receiver.

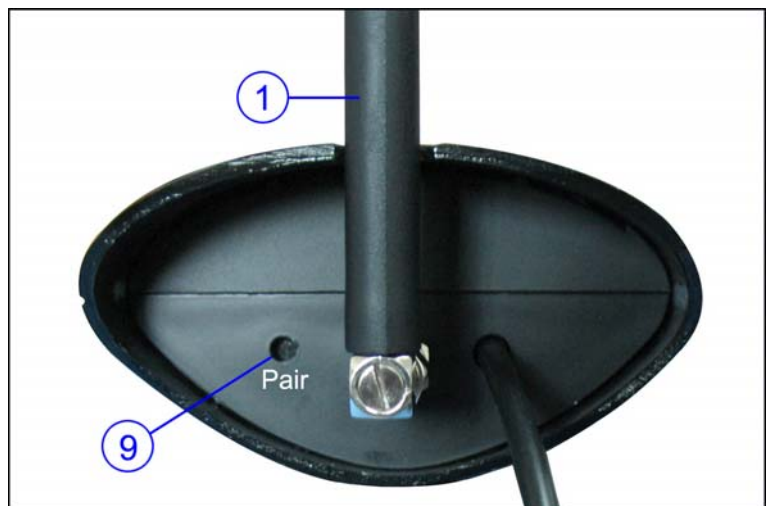
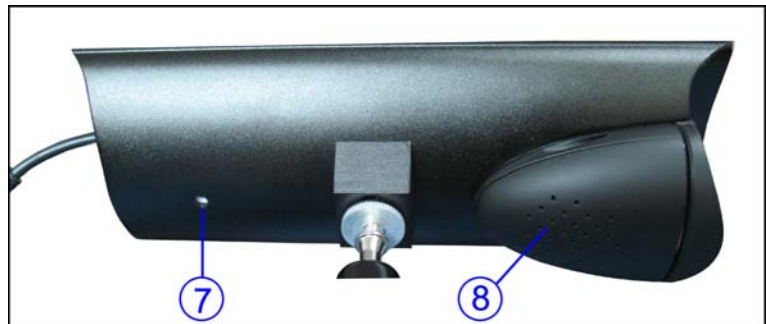

## Camera Installation

Before you install the camera, carefully plan where and how it will be positioned, and where you will route the cable that connects the camera to the power adaptor.

Before starting permanent installation, verify its performance by observing the image on the receiver when camera is positioned in the same location/position where it will be permanently installed and the receiver is placed in the location where it will be used most of the time.

## Installation Warnings

Aim the camera(s) to best optimize the viewing area: Select a location for the camera that provides a clear view of the area you want to receive, which is free from dust, and is not in line-of-sight to a strong light source or direct sunlight.

Avoid installing the cameras where there are thick walls, or obstructions between the cameras and the receiver.

## Night Vision

This camera has built-in IR LEDs, which provides the camera with the ability to view images in no/low light conditions. Night vision will be automatically switched on in low illumination condition.

## Installing the Camera

1. Carefully unpack the camera.

NOTE: If you are installing cameras that did not come with the system, please see the pairing camera section of this manual for installation details.

2. Mount the camera to the wall.

Mark the position of the screw holes on the wall, drill holes and insert the supplied 3 plastic anchors, then firmly fix the camera bracket to the plastic anchors with supplied screws.

3. Adjust the viewing angle of the camera

You can adjust the viewing angle to monitor desired area by rotating the camera bracket. Here are some templates:



4. Connect camera power

After the camera is installed, plug the AC adaptor power output cable into the 9V POWER jack of the camera, and plug the power plug into a wall outlet or surge protector.

**NOTE:** You can install additional cameras (maximum of 4 cameras). When adding cameras that were not included in the original box, you will need to pair the cameras with the receiver. Refer to the camera pairing section of this manual.

Camera installation is now completed.

## Remote Control

The remote control is supplied to operate the receiver. It includes all the operations on the receiver except talking back to camera.

Note: When using remote control, it is recommended to have it point at the IR reception port.

**Quad** – Press **Quad** button to view the images in quad mode. Press **(Channel) A**, **(Channel) M** or **Quad** button again to exit from quad mode.

**Menu** – Press to access the receiver menu. Press the button again to exit.

**Enter** – In viewing mode, press to enter playback interface for recorded videos.

**Navigation/Enter** – Use the buttons to control the receiver in Quad Mode, Menu Mode and Playback mode.

- **Quad Mode:** In quad mode, press a navigation button to view the image from the corresponding camera in full screen mode.

- **Menu Mode:** Use the navigation buttons to navigate in Menu Mode. Press the **Enter** button to confirm the menu selection.

- **Playback Mode:** In playback mode, use the navigation buttons to play/pause, stop, forward, backward.

**Scan/Del** – In viewing mode, press the button to switch the receiver to scan mode. In scan mode the LCD screen is turned off or displays a static picture, and the system continuously scans all available cameras. The indication LED on **SCAN** button will be on.

If motion is detected by the camera(s), the receiver will beep and display the image from the triggered camera. The receiver will return to scan mode about 5 seconds after the alarm has completed. Press **Scan**, **(Channel) A** or **(Channel) M** buttons will cancel scan mode.

In playback interface, press the button to delete recorded files from SD card.

**(Record) Motion** – Press the button to switch the system to automatic recording mode. In this mode, the indication LED **AUTO REC** will be on and the receiver starts recording when motion detected by a camera. The recording time can be set to 15s or 30s.

**(Record) ●** – Press the button to start recording, press it again to stop recording.

**(Channel) A** – Press the button to view cameras in automatic switching mode.

**(Channel) M** – Press the button to manually switch between all activated cameras.

**AV** – When connecting the receiver to TV or VCR/DVR, press the button to output audio/video. When outputting audio and video, the LCD screen will be switched to blank.

**Vol- / Vol+**: Press the buttons to adjust the volume.





## Viewing Mode

**1. Signal Indicator** – The signal indicator shows the strength of the signal being received from the camera.

### Signal Indicators:

Signal Strength	Indicator	Warning
Perfect		None
Good		None
Fair		Low Signal
Low		Low Signal
No Signal		No Signal

**2. Recording Indicator** – When the receiver is recording, the red indicator ●REC will be shown on the LCD screen. And under the indicator, you can see the name of the recorded file.

**3. SD Card Indicator** – When a SD card is inserted into the SD card slot, the indicator will be shown on the LCD screen.

**4. Power Failure Indicator** – Flashing icon indicates a power failure has occurred on the system. You may need to manually restore settings or modes on the system after a power failure.

**5. New Record Indicator** – When there is new recorded file, the indicator will be shown on the LCD screen and flashes to alert users.

**6. Channel Indicator** – Displays the current channel number. Press the **(Channel) M** button on the remote control to switch between available cameras.

Note: To automatically switch between channels, press the **(Channel) A** button on the remote control.



### No Signal Warning

When the receiver can't get signal from cameras, warning message will be displayed. Reposition the camera, or check the camera power connection.



### Quad Mode Warning

When switching the system to quad mode, warning message will be displayed. Users can't set schedule recording in quad mode.

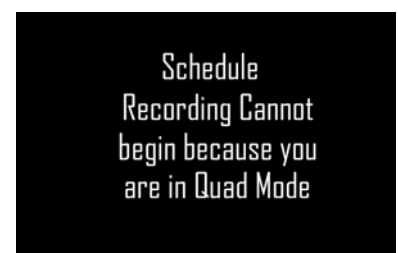

## SD Card Recording

The system is designed for SD card recording. You can manually record the video at your desire or the receiver records when there is motion detected by the cameras. Before recording, you need to insert a SD card to the SD card slot. The system can support the size of up to 16GB SD card.

### Recording Mode

#### Auto Recording

Press **(Record) Motion** button on the remote control to set the system to automatic recording mode. In this mode the receiver starts recording when motion detected by any activated camera. The recording time can be set to 15s or 30s after last detection.

In quad mode, when motion is detected by a camera, the receiver switched to display the image from the camera in full screen status and starts recording. After recording, it automatically switches back to quad mode. Press **(Record) Motion** button again to cancel automatic recording mode.

#### Manual Recording

Press **(Record) ●** button on the remote control, the receiver starts recording. Press the button again to cancel manual recording.

#### Schedule Recording

Set the recording start time and end time, then switch on schedule recording in the menu to enable schedule recording. In this mode the receiver records at a certain time each day.

### Playback

When there is new recorded file, the indication icon on the LCD screen appears and flashes to alert the users.

Follow the steps to play the recorded files.

- 1). In viewing mode, press the **Enter** button on the remote control or the joystick on the receiver to enter the operation interface.
- 2). Select the folder **VIDEO** and press **Enter**. You will see some folders name by date. For example: 080101 means the videos in this folder are recorded on January 1<sup>st</sup>, 2008.
- 3). Select a folder and press **Enter** to enter submenu. You will see the recorded files named by time. For example: 101024\_1 means the video is recorded at 10:10:24 and from camera 1.
- 4). Select the video you want to view and press **Enter** button, the video will be played on the LCD screen. Then you can use the navigation buttons to play/pause, stop, forward, backward.



## Accessing Menu System

The functions of the **Menu** button and navigation buttons/**Enter** button on the remote control are the same as the joystick and **Menu** button on the receiver. In this section we take the remote control as example to show the menu operation.

Press the **Menu** button on the remote control to enter menu system. Use the navigating buttons to navigate up/down/left/right in the menu, and press the **Enter** button to confirm a setting or selection.

### Main Menu

The Main Menu contains 4 submenus:

- 1. Camera On/Off** – Use the menu to switch on or switch off a specified camera.
- 2. Record** – Use the menu for SD card recording settings.
- 3. Pairing** – Use the menu to add camera(s) to the receiver.
- 4. Setting** – Use the menu for system settings, such as alarm volume, brightness and date & time setting.

### Camera On/Off Menu

Select a camera by pressing the UP ▲ or DOWN ▼ button, then pressing LEFT ◀ or RIGHT ▶ button to switch on or switch off the camera. Press the **Enter** button to confirm the change and exit.

### Record Menu

You can set up the recording parameters in record menu.

Note: To use the recording function, make sure a SD card is inserted into the SD card slot. When there is new video recorded, the indication icon on the LCD screen will flash to alert you.

- **Quality:** The resolution of recorded videos. There are two options: 320 x 240 pixels and 640 x 480 pixels.

Record videos are much clearer in 640 x 480 pixels mode but more fluent in 320 x 240 pixels mode.

- **Trigger Record:** The recording time when there is motion detected by a camera in automatic recording mode. The recording time can be set to 5s, 15s or 30s.



- **Schedule Record:** Set the schedule recording time for each day. Time can be set from 00:00 to 23:59. Then select the menu **ON** to enable schedule recording.



- **Overwrite:** Decide whether to cover the initial recorded files when SD card is full of memory.



### Pairing Menu

The system comes with camera(s) that have already been paired. The pairing function assigns each camera to a different channel on the wireless receiver (up to 4 cameras), and is necessary for configuring additional cameras.

Use the UP ▲ or DOWN ▼ button to select the desired pairing channel, and press the **Enter** button to begin the pairing process with a camera.



NOTE: It is highly recommended to pair the cameras to the receiver before permanently mounting the cameras. See the pairing section of this manual for details.

### Setting Menu

The **Setting** menu contains 8 submenus:



- **Date & Time:** Use LEFT◀ and RIGHT ▶ buttons to select the item, and use UP ▲ and DOWN ▼ buttons to set the time.



- **Brightness:** The Brightness Menu is used to adjust the brightness. Use the LEFT◀ and RIGHT ▶ buttons to change the bar from DARKEST (left) to LIGHTEST (right). Press the **Enter** button to confirm the adjustment.



- **AV Out:** Select the TV system when outputting the video/audio to TV, DVR/VCR or other viewing/recording devices.



- **Screen Saver:** 5 pictures are stored in the system. You can select one picture to make it be shown on the LCD screen in scan mode. Or you can select **Blank screen** to make the LCD screen display nothing in scan mode.



- **Alarm Volume:** Receiver beeps to alert you when motion detected by camera. Press LEFT ◀ or RIGHT ▶ button to increase or decrease the volume of the audio alarm.



- **Zoom:** The image can be set at original size or double size by selecting zoom x1 and zoom x 2. In double size mode, press the navigation buttons to view the parts out of the LCD screen.

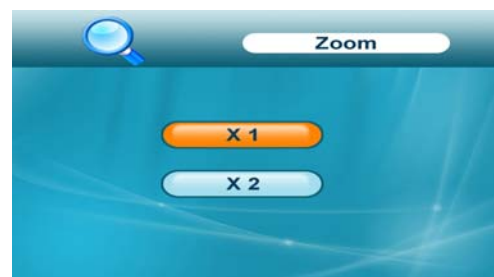

- **Format:** Select **Yes** to format the SD card. After formatting, all the data stored in the SD card will be deleted.

Note: Be cautious to use this function.



- **Default:** Select **Yes** to reset the receiver to factory defaults – all menu settings will be reset.



## Camera Pairing

The system comes with camera(s) that have already been paired. These cameras will communicate with the receiver once powered on.

The pairing function assigns each camera to a different channel on the wireless receiver (up to 4 cameras), and is necessary for configuring additional cameras.

NOTE: It is highly recommended to pair the cameras to the receiver before permanently mounting the cameras.

1. Power on the receiver by connecting it to power outlet with supplied 5V power adaptor.
2. Power on the camera by connecting it to power outlet with supplied 9V power adaptor.

3. Press the **Menu** button on the receiver or remote controller. Navigate to the **Pairing** menu option by pressing the ▼▲◀▶ buttons on the remote controller or operating the joystick on the receiver. Press the **Enter** button to enter the pairing operation.



4. Select a channel by pressing the UP and DOWN ▼▲ buttons on the remote controller or pushing upwards/downwards the joystick on the receiver. Press the **Enter** button to confirm the selection.



5. A message will be displayed on the receiver screen. The receiver will count down from 30~0 – you must press the **Pair** button on the camera during this time to successfully pair the camera.



If the button on the camera is not pressed, the receiver will return to the view screen, and no pairing will take place.

6. Press the **Pair** button on the back of the camera.

Once the camera has been paired, it will be immediately viewable on the receiver monitor.



## Troubleshooting

If you have problems with the system, there is often a quick and simple solution. Please try the following:

Problem	Solution
No picture from a camera	<ol style="list-style-type: none"> <li>1. Check all connections to the camera. Make sure the adaptor is plugged in.</li> <li>2. Make sure that the receiver is ON.</li> <li>3. Make sure that the camera is in range of the receiver.</li> </ol>
The picture is dropping	<ol style="list-style-type: none"> <li>1. Move the camera closer to the receiver.</li> <li>2. Try repositioning the camera, receiver or both to improve the reception.</li> </ol>
Audio problems	<ol style="list-style-type: none"> <li>1. Increase the volume when there is no sound.</li> <li>2. Make sure that there is sound within range of the camera microphone.</li> <li>3. If the unit emits a loud screeching noise (audio feedback), move the camera or receiver farther apart.</li> </ol>
The picture is or has become choppy	<p>The picture may become choppy when experiencing a lower frame rate (i.e. 10 frames per second vs. a higher 20 frames per second). Try moving the camera closer to the receiver. Remove obstructions between the receiver and camera.</p>
The Picture appears to be grainy when using AV out function to view on a large screen TV/Monitor	<p>The purpose of the AV output is for convenience only. When using with large screen TV/Monitor, the picture might be grainy as the camera limits video resolution to VGA (640x480 pixels). This is not a product defect.</p> <ol style="list-style-type: none"> <li>1. For best performance use with TV/Monitor PIP (Picture in Picture) function. Check your TV/Monitor product manual to see if this feature is available on your TV/Monitor.</li> <li>2. View video on a smaller screen TV/Monitor.</li> </ol>
Recording Problems	<ol style="list-style-type: none"> <li>1. Make sure the SD card is inserted to SD card slot correctly.</li> <li>2. Check the SD card is not full of memory.</li> <li>3. Make sure the size of SD card is compatible with the system. The system can support up to 16GB SD card.</li> </ol>

## Appendix #1 – System General Specifications

Operating Frequency Range	2.400GHz~2.483GHz
TX Power	14dBm
RX Sensitivity	-81dBm
Type of Spread Spectrum Used	FHSS
Type of Modulation Used	GFSK
Data Rate	2Mbps
Communication Range	100m Line in Sight

## Appendix #2 - Receiver Specifications

Display Size/Type	7" TFT LCD
Resolution	H: 480 RGB, V: 234
Viewing Angle	H: 145 degree, V: 115 degree
A/V Output Resolution/ Frame Rate	VGA/ QVGA Selectable
Power Requirement	5.0Vdc +/-10%
Power Consumption	850mA Max
Operating Temp Range	-10~50 degree C
Operating Humidity Range	Within 85%RH
Dimension	182mm x 65mm x 138mm
Regulation Compliance	FCC/ CE
RoHS Compliance	Yes
Housing Material	ABS Plastic

## Appendix #3 - Camera Specifications

Camera(s)	
Image Sensor Type	1/4" Color CMOS Image Sensor
Effective Pixel	H: 640, V: X: 480,
Image Resolution	H: 640, V: 480 @ 9fps. H:320, V: 240 @25fps
Lens	4.5mm F 2.0
AGC	Auto
AES Speed	1/60~1/15,000 Sec
White Balance	Auto
Power Requirement	9V DC +/-10%.
Power Consumption	Max 350mA with IR LED, Max 145mA without IR LED.
Operating Temp Range	-10~50 degree C
Operating Humidity Range	Within 85%RH
Dimension	185mm x 68mm x 38mm
Environment Rating	IP56
Regulation Compliance	FCC/ CE
RoHS Compliance	Yes
Camera Housing Material	Aluminum